

型号 Model: AM520E

应用范围: 电动吸奶器、家用电器

Application scope: Electric breast pump
household appliances

产品照片 Photo



产品尺寸 Dimension

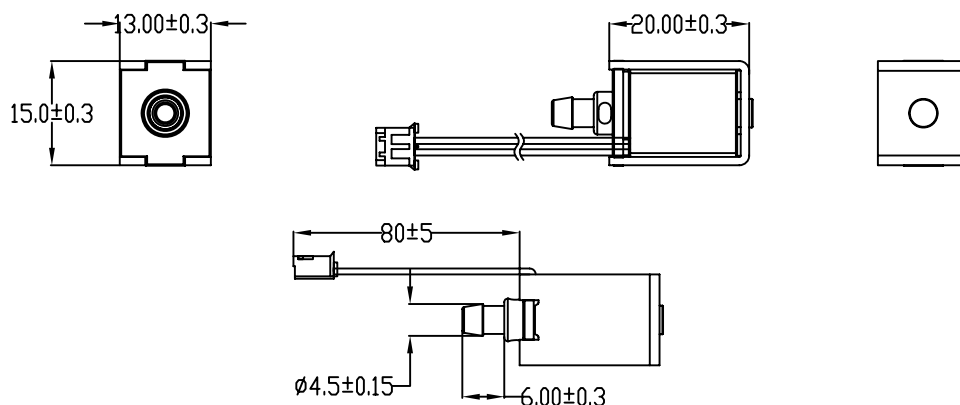

产品特性 Characteristic

额定电压 Rated Voltage	DC6.0V
额定电流 Rated Current	350mA
阻抗 Resistance	17 Ω ± 10%
工作压力 pressure	<-450mmHg max.
气密性 Leakage	Max. 3mmHg/min from 300mmHg at 500CC tank.
绝缘等级 Insulation Level	A
使用流体 Apply For	Air
寿命 Life	200, 000 Times
使用环境 Environment	0~50 °C, 75% RH